

Agilent Technologies 11612V Option K22 and K23

User's Guide



Agilent Technologies

Manufacturing Part Number: 11612-90071

Printed Date: July 2010

Supersede June 2010

© Copyright Agilent Technologies, Inc. 2008, 2010

Warranty Statement

THE MATERIAL CONTAINED IN THIS DOCUMENT IS PROVIDED “AS IS,” AND IS SUBJECT TO BEING CHANGED, WITHOUT NOTICE, IN FUTURE EDITIONS. FURTHER, TO THE MAXIMUM EXTENT PERMITTED BY APPLICABLE LAW, AGILENT DISCLAIMS ALL WARRANTIES, EITHER EXPRESS OR IMPLIED WITH REGARD TO THIS MANUAL AND ANY INFORMATION CONTAINED HEREIN, INCLUDING BUT NOT LIMITED TO THE IMPLIED WARRANTIES OF MERCHANTABILITY AND FITNESS FOR A PARTICULAR PURPOSE. AGILENT SHALL NOT BE LIABLE FOR ERRORS OR FOR INCIDENTAL OR CONSEQUENTIAL DAMAGES IN CONNECTION WITH THE FURNISHING, USE, OR PERFORMANCE OF THIS DOCUMENT OR ANY INFORMATION CONTAINED HEREIN. SHOULD AGILENT AND THE USER HAVE A SEPARATE WRITTEN AGREEMENT WITH WARRANTY TERMS COVERING THE MATERIAL IN THIS DOCUMENT THAT CONFLICT WITH THESE TERMS, THE WARRANTY TERMS IN THE SEPARATE AGREEMENT WILL CONTROL.

DFARS/Restricted Rights Notice

If software is for use in the performance of a U.S. Government prime contract or subcontract, Software is delivered and licensed as “Commercial computer software” as defined in DFAR 252.227-7014 (June 1995), or as a “commercial item” as defined in FAR 2.101(a) or as “Restricted computer software” as defined in FAR 52.227-19 (June 1987) or any equivalent agency regulation or contract clause. Use, duplication or disclosure of Software is subject to Agilent Technologies’ standard commercial license terms, and non-DOD Departments and Agencies of the U.S. Government will receive no greater than Restricted Rights as defined in FAR 52.227-19(c)(1-2) (June 1987). U.S. Government users will receive no greater than Limited Rights as defined in FAR 52.227-14 (June 1987) or DFAR 252.227-7015 (b)(2) (November 1995), as applicable in any technical data.

Safety Notes

The following safety notes are used throughout this document. Familiarize yourself with each of these notes and its meaning before performing any of the procedures in this document.

WARNING	Warning denotes a hazard. It calls attention to a procedure which, if not correctly performed or adhered to, could result in injury or loss of life. Do not proceed beyond a warning note until the indicated conditions are fully understood and met.
----------------	---

CAUTION	Caution denotes a hazard. It calls attention to a procedure that, if not correctly performed or adhered to, could result in damage to or destruction of the instrument. Do not proceed beyond a caution sign until the indicated conditions are fully understood and met.
----------------	---

Definitions

- *Specifications* describe the performance of parameters covered by the product warranty (temperature –0 to 55 °C, unless otherwise noted.)
- *Typical* describes additional product performance information that is not covered by the product warranty. It is performance beyond specification that 80% of the units exhibit with a 95% confidence level over the temperature range 20 to 30 °C. Typical performance does not include measurement uncertainty.
- *Nominal* values indicate expected performance or describe product performance that is useful in the application of the product, but is not covered by the product warranty.
- *Characteristic Performance* describes performance parameter that the product is expected to meet before it leaves the factory, but is not verified in the field and is not covered by the product warranty. A characteristic includes the same guard bands as a specification.

Contents

11612V K22/K23

Description	2
Verifying the Shipment	2
Typical Performance	3
Bias Network	4
Safety and Regulatory Information	5
Introduction	5
Cleaning the Instrument	5
Connector Care and Cleaning	5
Statement of Compliance	5
General Safety Considerations	6
Cautions	6
Servicing	6
Regulatory Information	6
Instrument Markings	6
Electrostatic Discharge Protection	7
Agilent Support, Services, and Assistance	8
Service and Support Options	8
Contacting Agilent	8
Shipping Your Instrument to Agilent for Service or Repair	8

Contents

11612V K22/K23

Description

The Agilent 11612V Option K22 and K23 are a 50 GHz bias network with force/sense bias capability. The Option K22/K23 provides a force connection to allow input of a current (≤ 2 Amps) or voltage signal, and a sense connection to allow monitoring of voltage or current. A ground connection for application of an active ground is also provided. The force, sense, and ground are triaxial connectors.

When used as part of the 85122A system, the bias network is intended to be connected to cables from the SMUs in the 4142 DC source/monitor. The force and sense connectors on the quadraxial cables from the SMUs are connected to the force and sense connectors on the bias network. The triaxial cable from the GNDU is connected to the ground connector on the bias network.

The RF connectors on the bias network are 2.4 mm (f) connectors. The 11612V Option K22 is intended for use at Port 1 and Option K23 for use at Port 2 of the network analyzer. The RF cable from the network analyzer test port is connected to the RF IN port of the bias network. The RF OUT port of the bias network is connected to the probes, or the fixture, or the device itself.

Verifying the Shipment

To verify the contents shipped with your product, refer to the “Box Content List” included with the shipment.

Inspect the shipping container. If the container or packing material is damaged, it should be kept until the contents of the shipment have been checked mechanically and electrically. If there is physical damage refer to [“Contacting Agilent” on page 8](#). Keep the damaged shipping materials (if any) for inspection by the carrier and an Agilent Technologies representative.

Typical Performance

WARNING If any of the maximum ratings are exceeded, damage may occur to the bias network assembly.

Performance parameters (subject to change) are typical over a temperature range of 20 to 30 °C.

Table 1 Performance Parameters

Description	Typical (dB)
S11 Port 1 (RF Input) and S22 Port 2 (RF & DC Output) Return Loss	
Return Loss (400 MHz to 1 GHz)	12 dB Min
(1 to 18 GHz)	15 dB Min
(18 to 26.5 GHz)	10 dB Min
(26.5 to 50 GHz)	9 dB Min
Insertion Loss (0.4 to 12.4 GHz)	
(12.4 to 26.5 GHz)	4 dB Max
(26.5 to 50 GHz)	7.0 dB Max
Maximum DC Current	2.0 Amps
Max Voltage	100 Vdc
Max RF Power	2 Watts (+33 dBm)

Figure 1 Dimensions

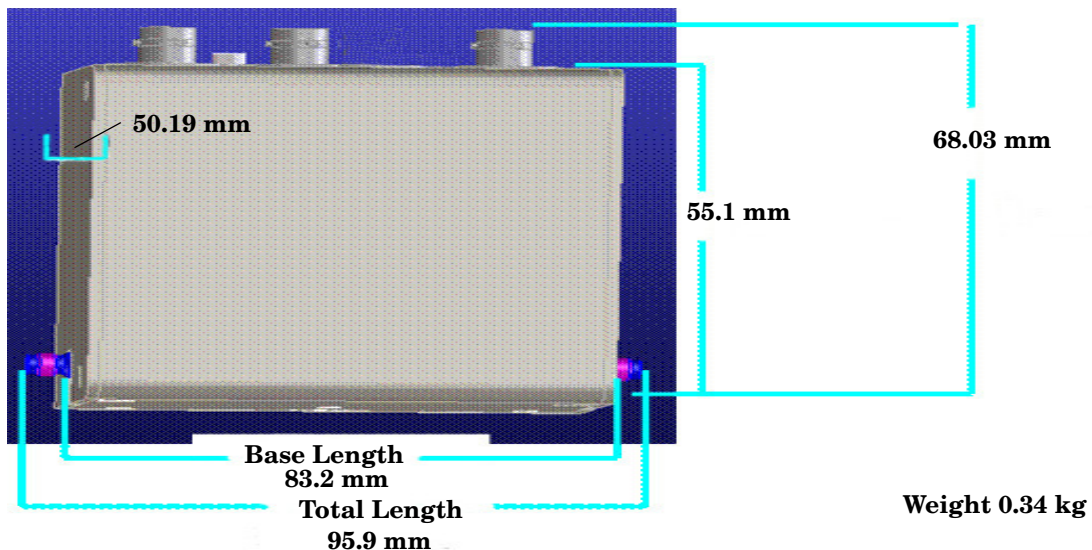

Bias Network

Internally, each bias network includes two bias-tees, one for force and one for sense. The force bias-tee includes a capacitor that functions as a DC block and highpass filter. The sense bias-tee provides a through path for DC voltage. Oscillation suppression networks are located on each DC path to help prevent bias oscillation of the DUT. [Figure 2](#) is a schematic diagram of the bias network.

Figure 2 Diagram of the 11612V Option K22/K23 Bias Network

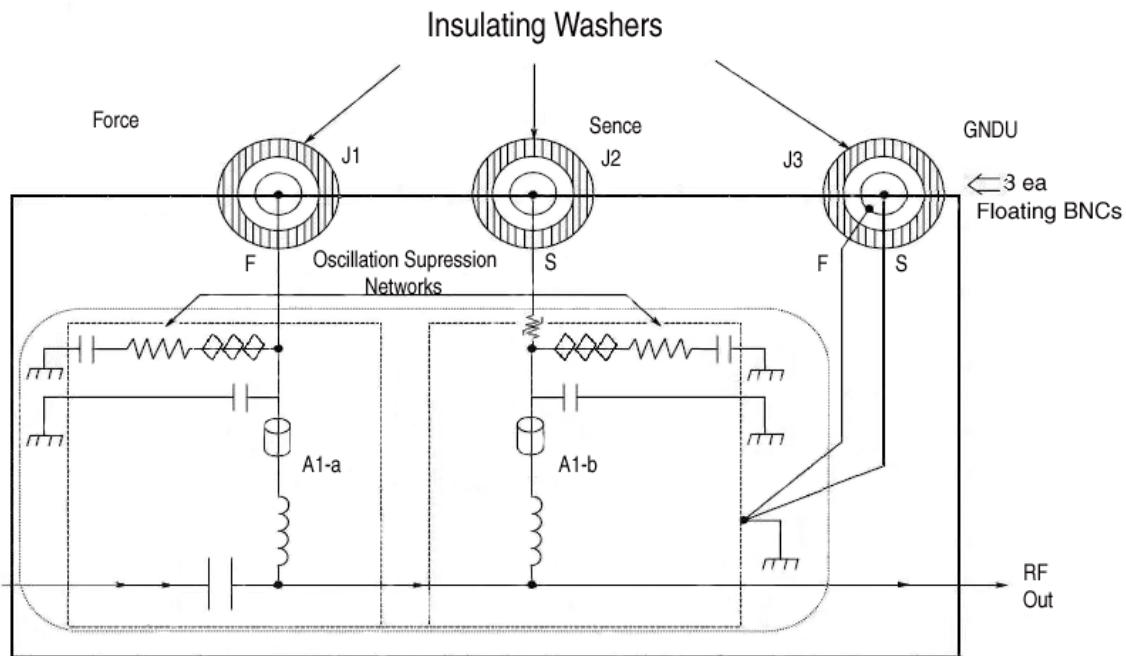

Safety and Regulatory Information

Introduction

Review this product and related documentation to familiarize yourself with safety markings and instructions before you operate the instrument. The documentation contains information and warnings that must be followed by the user to ensure safe operation and to maintain the product in a safe condition.

Cleaning the Instrument

WARNING Use a dry cloth or one slightly dampened with water to clean the external case parts. Do not attempt to clean internally.

Connector Care and Cleaning

Cleaning connectors with alcohol shall only be done in a well ventilated area. Allow all residue alcohol moisture to evaporate and the fumes to dissipate prior to energizing the instrument.

WARNING Keep isopropyl alcohol away from heat, sparks, and flame. Store in a tightly closed container. It is extremely flammable. In case of fire, use alcohol foam, dry chemical, or carbon dioxide; water may be ineffective.

Statement of Compliance

This instrument has been designed and tested in accordance with CAN/CSA 22.2 No. 61010-1-04, UL Std No. 61010-1 (Second Edition), and IEC 61010-1 (Second Edition).

General Safety Considerations

Cautions

Cautions applicable to this instrument.

CAUTION This product is designed for use in Installation Category II and Pollution Degree 2.

Servicing

Warnings applicable to this instrument.

WARNING These servicing instructions are for use by qualified personnel only.

WARNING No operator serviceable parts inside. Refer servicing to qualified personnel.

WARNING If this product is not used as specified, the protection provided by the equipment could be impaired. This product must be used in a normal condition (in which all means for protection are intact) only.

Regulatory Information

This section contains information that is required by various government regulatory agencies.

Instrument Markings



The instruction documentation symbol. The product is marked with this symbol when it is necessary for the user to refer to the instructions in the documentation.



This symbol indicates separate collection for electrical and electronic equipment, mandated under EU law as of August 13, 2005. All electric and electronic equipment are required to be separated from normal waste for disposal (Reference WEEE Directive, 2002/96/EC).



Direct Current.



China RoHS regulations include requirements related to packaging, and require compliance to China standard GB18455-2001.



This symbol indicates compliance with the China RoHS regulations for paper/fiberboard packaging.

Electrostatic Discharge Protection

Protection against electrostatic discharge (ESD) is essential while removing assemblies from or connecting cables to the instrument. Static electricity can build up on your body and can easily damage sensitive internal circuit elements when discharged. Static discharges too small to be felt can cause permanent damage. To prevent damage to the instrument:

- *always* have a grounded, conductive table mat (9300-0797) in front of your test equipment.
- *always* wear a grounded wrist strap (9300-1367) with grounding cord (9300-0980), connected to a grounded conductive table mat, having a 1 M Ω resistor in series with it, when handling components and assemblies or when making connections.
- *always* wear a heel strap (9300-1126) when working in an area with a conductive floor. If you are uncertain about the conductivity of your floor, wear a heel strap.
- *always* ground yourself before you clean, inspect, or make a connection to a static-sensitive device or test port. You can, for example, grasp the grounded outer shell of the test port or cable connector briefly.
- *always* ground the center conductor of a test cable before making a connection to the analyzer test port or other static-sensitive device. This can be done as follows:
 1. Connect a short (from your calibration kit) to one end of the cable to short the center conductor to the outer conductor.
 2. While wearing a grounded wrist strap, grasp the outer shell of the cable connector.
 3. Connect the other end of the cable to the test port and remove the short from the cable.

Figure 3 ESD Protection Setup

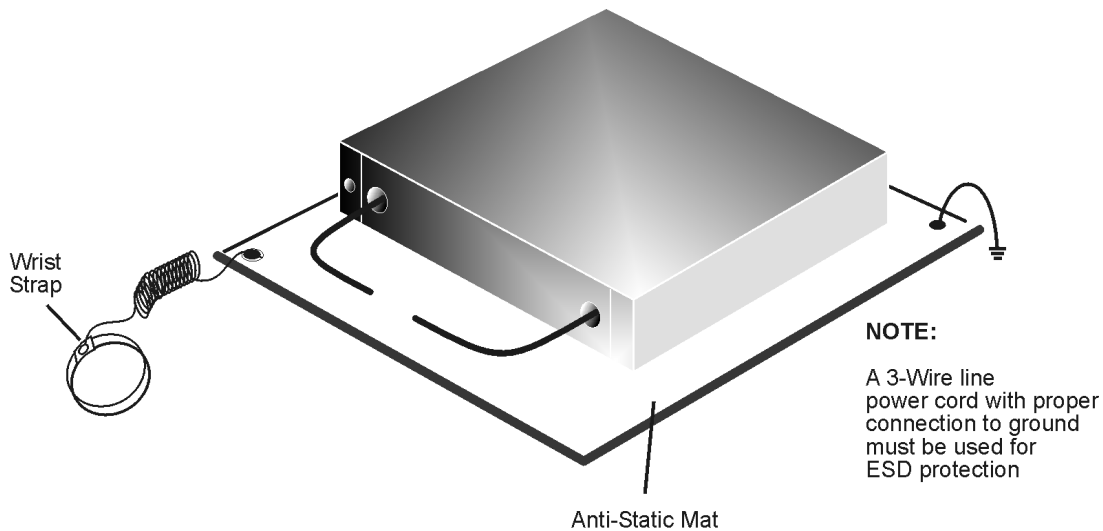

ku310b

Agilent Support, Services, and Assistance

Service and Support Options

The standard product warranty is a one-year return to Agilent Technologies service warranty.

NOTE There are many other repair and calibration options available from the Agilent Technologies support organization. These options cover a range of service agreements with varying response times. Contact Agilent for additional information on available service agreements for this product.

Contacting Agilent

Assistance with test and measurements needs and information or finding a local Agilent office are available on the Web at:

<http://www.agilent.com/find/assist>

You can also purchase accessories or documentation items on the Internet at:

<http://www.agilent.com/find>

If you do not have access to the Internet, contact your field engineer.

In any correspondence or telephone conversation, refer to the Agilent product by its model number and full serial number. With this information, the Agilent representative can determine the warranty status of your unit.

Shipping Your Instrument to Agilent for Service or Repair

IMPORTANT Agilent Technologies reserves the right to reformat or replace the internal hard disk drive in your analyzer as part of its repair. This will erase all user information stored on the hard disk. It is imperative, therefore, that you make a backup copy of your critical test data located on the analyzer's hard disk before shipping it to Agilent for repair.

If you wish to send your instrument to Agilent Technologies for service or repair:

- Include a complete description of the service requested or of the failure and a description of any failed test and any error message.
- Ship the analyzer using the original or comparable antistatic packaging materials.
- Contact Agilent for instructions on where to ship your analyzer.